

PROCESS SOLUTIONS
FOR HOTMELT COOLING



DrumCooler **Type CCC-110/150**
Type CCC-150/150
Type CCC-180/150

The DrumCooler types CCC are designed for continuous cooling and solidification of viscous products. They are distinguished by its high cooling efficiency as well as its minimum space requirement and small footprint.

The product, which has been rolled out into a thin film, is pressed up against the surface of a cooled drum and is fed into a crusher unit.

Your benefits

- Compact design
- Closed water loop of cooling media
- Adjustable calender nip to control product layer thickness
- Special design featuring easy access and quick cleaning
- Narrow distribution of the chip sizes

- Throughput	CCC-110/150	CCC-150/150	CCC-180/150
	1.200 kg/h*	1.600 kg/h*	2.200 kg/h*

*depends on specific product and production parameters

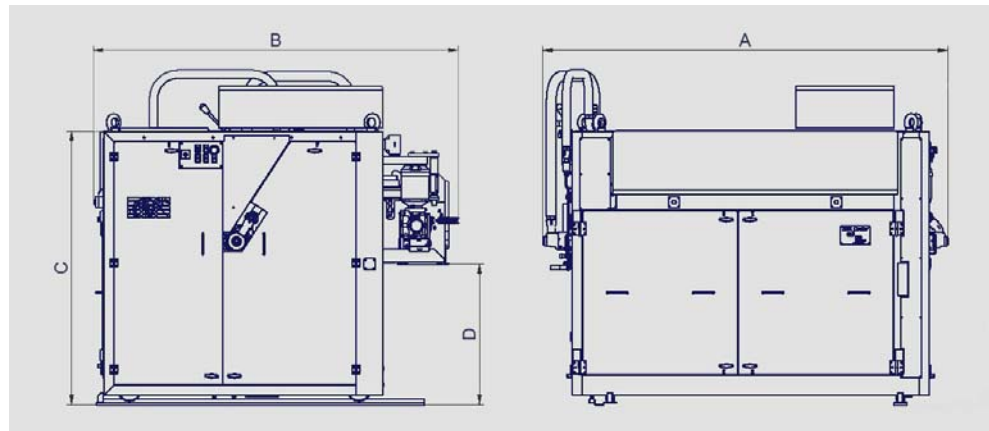

Technical data:

		CCC-110/150	CCC-150/150	CCC-180/150
Overall width	A		2475 mm	
Overall length	B	2250 mm	2742 mm	3020 mm
Product inlet height	C	1720 mm	2142 mm	2370 mm
Discharge height	D	860 mm	1100 mm	1460 mm
Width of cooling drum			1500 mm	
Ø Squeezing drum			260 mm	
Ø Cooling drum		1100 mm	1500 mm	1800 mm
Power consumption			3 kW	
Total net weight				

Options:

- Micro-crusher shaft
- Special material layer on drums available
- Condensate remover

